

SUPER STALLION 6X4

Super Stallion 6x4 is a Heavy duty tractor dedicated to operate in highway application under abnormal weather conditions . It is fitted with N6 engine, 16 speed GB, Hub reduction axles and pneumatic brakes with ABS that provides excellent mobility, ground clearance and maneuverability.

GCW : 51 T | PAYLOAD : 41 T | CAB : 2+2



DIMENSIONS

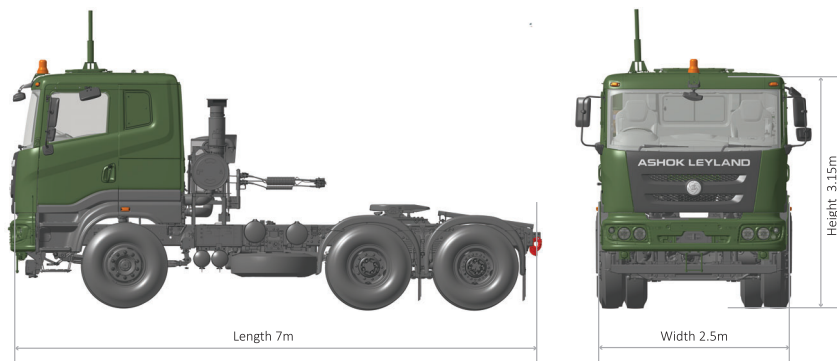

MOBILITY PERFORMANCE

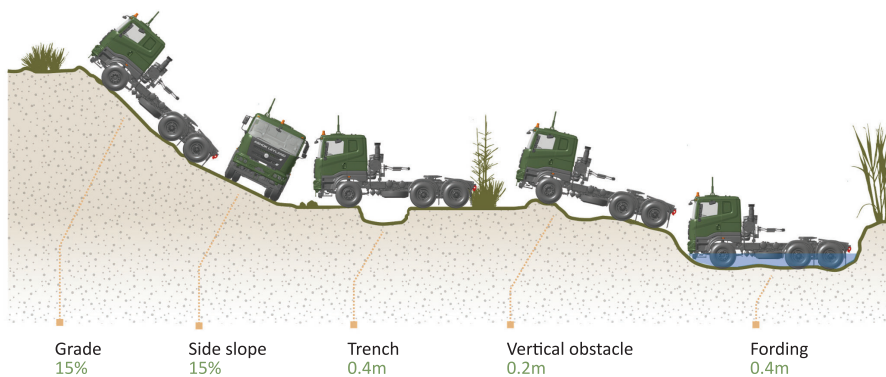

APPLICATIONS

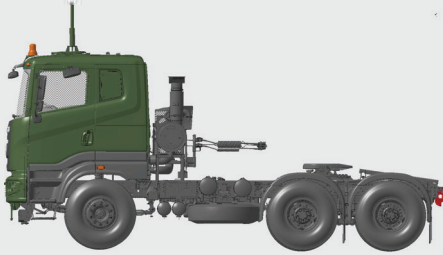

4936 TRACTOR

Application: Various
Engine Power: 360 HP
Feature: Heavy Duty Tractor

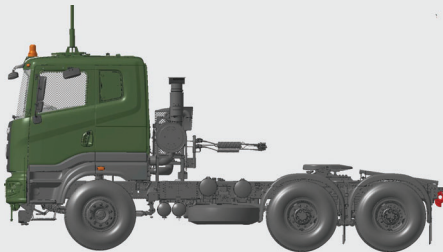

4945 TRACTOR

Application: Various
Engine Power: 450 HP
Feature: Heavy Duty Tractor

OPTIONS



Air conditioning and heated cab



Antenna Mount / Jammer Mount



Rotating Beacon



NBC protection system with masks



Automatic transmission



ABS



Rear View Camera with GPS



Search Light on Roof (Motorized /Manual)